

SPEC SHEET

PRODUCT DESCRIPTION

- Lighted (LED strip) mirror with metal frame and shelf
- Stainless steel construction
- 3 color light switch + dimming function
- Antifog function
- 5mm thick high quality copper free mirror
- Hard-wired electrical installation
- Connection to a light switch is optional (not intended for use with dimmers)
- LED intensity is 55 foot candle (600 lux) at standard user distance
- LED life is 50,000 hours
- Features 3000K, 5000K, and 7000K color temperatures
- CRI 80+
- Uses 75 watts
- Two year manufacturer warranty
- ETL and IP44 rated and certified (LED, drivers, and switches)
- Aluminum french cleat mounting system

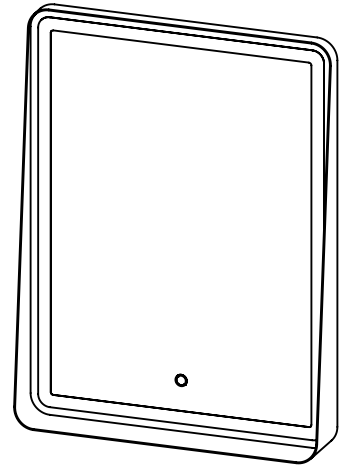

ROUGHING-IN DIMENSIONS

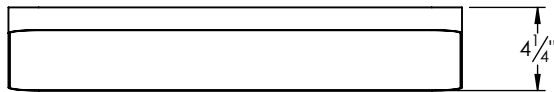

TOP VIEW

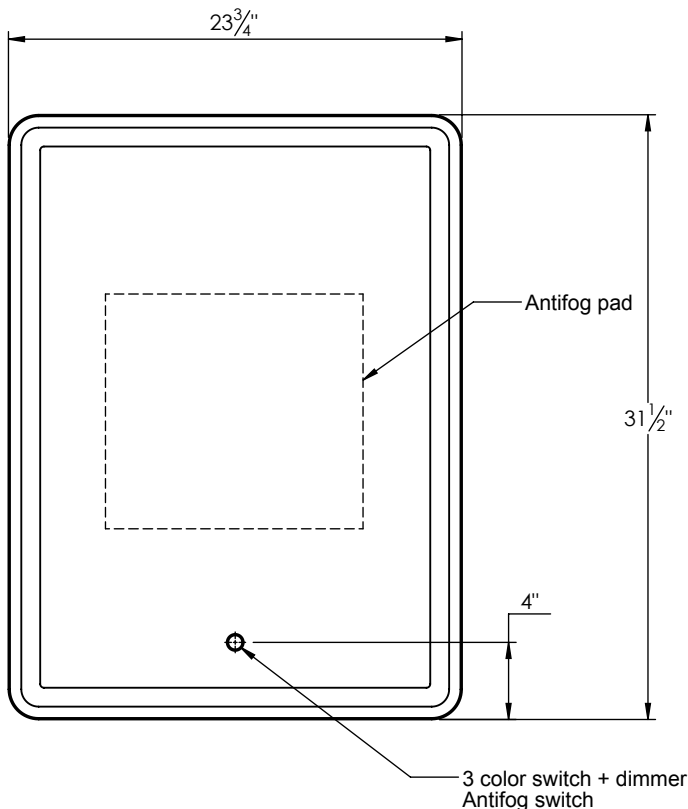

FRONT VIEW

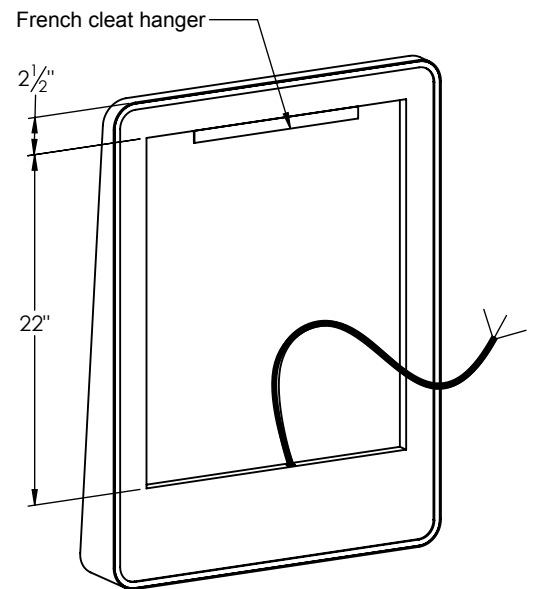

REAR VIEW